

### Product Identification and Overview

The BAPI-Stat 4MB Modbus room temperature or temperature/humidity sensor is available with optional large-format LCD, pushbutton setpoint, override and fan speed adjustments.

The available (and enabled) process variables are available via standard RS485 network using an industry standard Modbus RTU protocol.

Communications parameters and user limits are set up through an included Page parameter adjustment system.

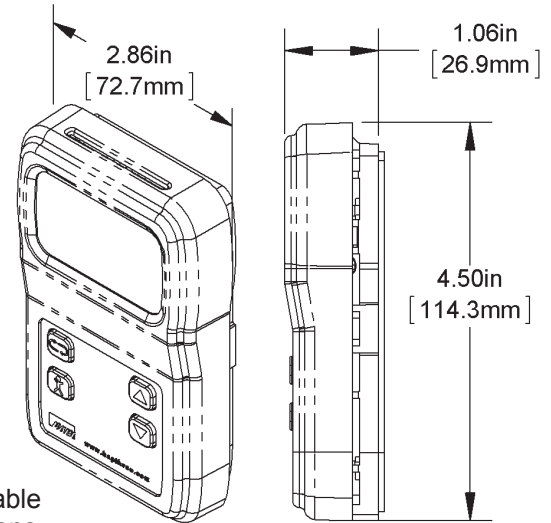

**Fig. 1:**  
BAPI-Stat 4MB Modbus  
unit with Display,  
Setpoint and Override.

**Note:** Unit is also available  
without display and buttons.

### Mounting

#### JUNCTION BOX

1. Pull the wire through the wall and out of the junction box, leaving about 6 inches free. Pull the wire through the hole in the base plate.
2. Secure the base to the box using the #6-32 x 1/2 inch mounting screws provided.
3. Terminate the unit according to the guidelines in the **Termination** section.
4. Attach Cover by latching it to the top of the base, rotating the cover down and snapping it into place.
5. Secure the cover by backing out the lock-down screws using a 1/16" Allen wrench until they are flush with the bottom of the cover.

#### DRYWALL MOUNTING

1. Place the base plate against the wall where you want to mount the sensor. Mark the two mounting holes and the area where the wires will come through the wall.
2. Drill two 3/16" holes in the center of each marked mounting hole. Insert a drywall anchor into each hole.
3. Drill one 1/2" hole in the middle of the marked wiring area.
4. Pull the wire through the wall and out the 1/2" hole, leaving about 6 inches free. Pull the wire through the hole in the base plate.
5. Secure the base to the drywall anchors using the #6 x 1 inch mounting screws provided.
6. Terminate the unit according to the guidelines in the **Termination** section.
7. Attach Cover by latching it to the top of the base, rotating the cover down and snapping it into place.
8. Secure the cover by backing out the lock-down screws using a 1/16" Allen wrench until they are flush with the bottom of the cover.

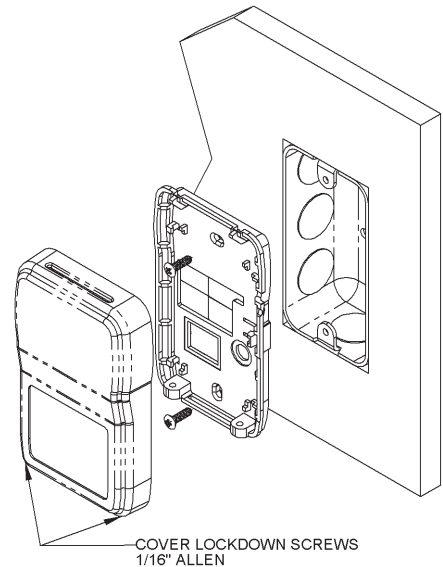

**Fig. 2:** Mounting hardware is provided for  
both junction box and drywall installation  
(junction box installation shown).

**NOTE:** In a wall-mount application, the mixing of room air and air from within the wall cavity can lead to erroneous readings, condensation, and premature failure of the sensor. To prevent this condition, plug the conduit hole with insulation in the junction box.



### Front Panel & Control Descriptions

The BAPI-Stat 4MB is available without display and without buttons, or with display and with four buttons - Setpoint Up/Down, Scroll and Override. Fig. 4 shows a fully featured unit. Individual LCD icons can be controlled via specific Modbus Registers.

#### Scroll Button Function and Flow

The default display shows current process value or a rotation of process values based on the Page 6 menu value. Use the Scroll button to index through the enabled sensor parameters. (See the Register Map on the last page for a list of allowable display parameters.) Parameters with the "SETPOINT" icon displayed are editable. Use the Up/Down buttons to change them, and use the Scroll button to view the next parameter or return to the normal display mode. When in the Pages mode, the Scroll button becomes the Enter button for entering a page and accepting changes within a page.

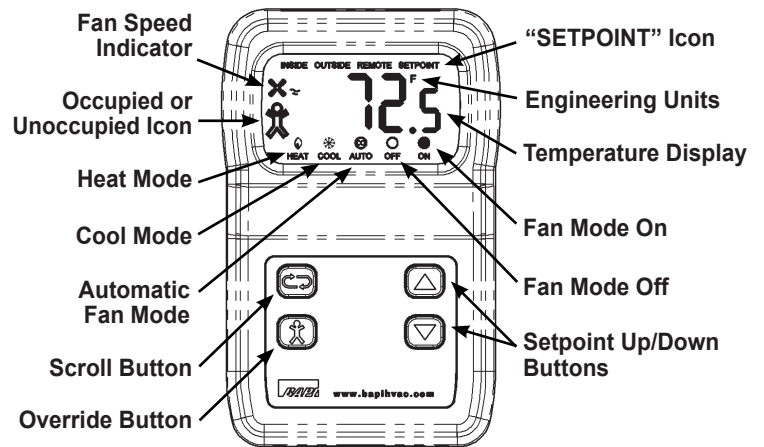

Fig. 4: BAPI-Stat 4MB Modbus Unit with Override, Setpoint and Scroll Buttons

#### BAPI-Man Icon

The BAPI-Man Icon can be used to show the zone status (see Fig. 5). The first Modbus write to Register 40, bit 0 (set to true) after power up will latch the BAPI-Man outline on. Future writes or button presses will only affect the interior of the BAPI-Man. Cycling power will reset the outline.

#### Up/Down Buttons

The Up/Down buttons are used to adjust editable parameters whether in the Page or Parameter/Setpoint modes.

#### Override Button:

If the Override feature is enabled then the BAPI-Man outline will be latched on and any Override button push will do the following. An Override button press will toggle both the inner portion of the BAPI-Man icon (Fig. 5) for 10 seconds and Register 20, bit 0. This bit and the icon are toggled again after 10 seconds. A Modbus write to Register 40, bit 0 can confirm the Override status and keep the BAPI-Man icon turned on (true) or off (false). If the Override feature is not enabled, setting Register 40, bit 0 to true will turn on the BAPI-Man icon, inner and outer. Setting the bit to false will clear the icon, inner and outer.

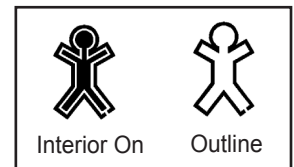

Fig. 5: BAPI-Man Icon

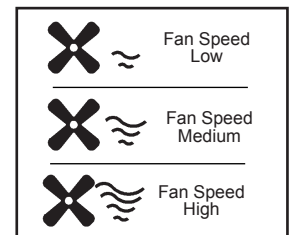

Fig. 6: Fan Speed Indicator

#### Dip Switch Options (see Fig. 7 on next page)

- **Switches 1 through 5** - Sets the binary Address for the device. Units are shipped with the Address set to 1. An Address of 0 is invalid. Additional Addresses are available using the Page 1 Menu (see pg 4).
- **Switch 6 (TOOL)** - Sets the unit in a Listen-Only Mode when set to On and returns the unit to Normal Operation when set to Off. The Firmware Version and Address are displayed (on LCD units) for a short period after the switch is set to Off.
- **Switch 7 (PROG)** - Sets the unit in Program Mode to access the PAGE Menus.
- **Switch 8 (F/C)** - Sets the display reading and the output temperature values to °F or °C.

#### Status and Network LEDs (see Fig. 3 on pg 2)

- **Status LED** - Green indicates that the unit is operating properly. Red indicates that there is a problem with the unit.
- **Network LED** - Flashing Red Slowly indicates that there has been no communications for 60 seconds. Flashing Green Slowly indicated that there have been normal communications within the last 60 seconds. Flashing Green Slowly with Quick Red Flashes indicates active communications.



### Optional Technician Adjustments

The unit is shipped ready to install per the order but may require some additional setup depending on the network and communications parameters used. The following Setup or Program Menu Changes are available if the installer decides to change the factory settings. **Note: For units without display and without pushbuttons, only Page Menus 1, 11, 12 and 13 are adjustable, and they are accessed through Modbus communications.**

#### ENTERING PROGRAM MODE TO ACCESS THE PAGE MENUS:

1. Remove cover and set DIP Switch #7 (PROG) to On (see Fig. 7).
2. Use the Up/Down buttons to advance to the parameter you wish to adjust.
3. Push the Scroll button to select the Page you want to view.
4. Use the Up/Down buttons to adjust the parameter
5. Push the Scroll button to select the newly adjusted parameter value.
6. To exit Program Mode, set DIP Switch #7 to Off.

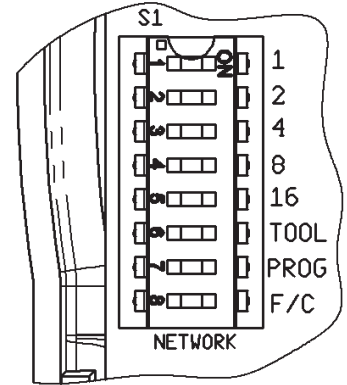

Fig. 7: Dip Switches

#### QUICK VIEW PAGE MENUS:

Menu	Title	Defaults
Page 1	Unit Address Offset	0
Page 2	Temperature Setpoint Low Limit	60°F
Page 3	Temperature Setpoint High Limit	80°F
Page 4	Humidity Setpoint Low limit	0%
Page 5	Humidity Setpoint High Limit	100%
Page 6	LCD Mode	t
Page 7	LCD Resolution	0.1
Page 8	LCD Cycle Rate	5
Page 9	Temperature Offset Adjustment	0.0
Page 10	Humidity Offset Adjustment	0.0
Page 11	Baud	57600
Page 12	Stop	1
Page 13	Parity	None
Page 14	Firmware Version	

#### EXPANDED PAGE MENU DEFINITIONS AND LIMITS:

Menu	Parameter	Description
P1	Unit Address Offset:	Selects the address offset for the unit Allowed values are (0, 32, 64, 96, 128, 160 and 192) Unit address is this value plus DIP switch setting.
P2	Temperature Setpoint Low:	Sets the lowest value that can be set by the user. Units (°C or °F) are selected via the DIP switch position 8 °F (-40 to 185), °C (-40 to 85)
P3	Temperature Setpoint High:	Sets the highest value that can be set by the user. Units (°C or °F) are selected via the DIP switch position 8 °F (-40 to 185), °C (-40 to 85)
P4	Humidity Setpoint Low:	Sets the lowest value that can be set by the user. (0 to 100%)
P5	Humidity Setpoint High:	Sets the highest value that can be set by the user. (0 to 100%)

Continued on next page...



# BAPI-Stat 4MB Modbus Temp or Temp/Humidity Sensor

Installation & Operating Instructions

34350\_ins\_BS4\_modbus

rev. 02/02/18

## Optional Technician Adjustments continued...

<u>Menu</u>	<u>Parameter</u>	<u>Description</u>
P6	.....LCD Mode: .....	Sets the type of values shown on the LCD. Non – Blank LCD t - Room temperature value only rH - Room relative humidity value only rHt - Room RH and room temperature value alternating
P7	.....LCD Resolution: .....	Selects the resolution for the LCD. 01 - Selects a 0.1 resolution. (xx.1). 05 - Selects a 0.5 resolution. (xx.5). 10 - Selects whole numbers for the resolution. (xx.0).
P8	.....LCD Cycle Rate:.....	Sets the cycle time for the LCD. (3 to 10 seconds)
P9	.....Temperature Offset:.....	Adjusts the measured temperature value. (-9.5° to +9.5° in 0.1° increments)
P10	.....Humidity Offset:.....	Adjusts the measured humidity value.(-9.5% to +9.5% in 0.1% increments)
P11	.....Baud:.....	Sets the communications speed for the RS485 network. (9600, 19200, 57600) shown as 96, 192 or 576
P12	.....Stop Bits:.....	Sets the number of stop bits required. (1 or 2)
P13	.....Parity:.....	Sets the type of parity used. (None, Odd or Even) shown as non, odd or EE
P14	.....Sensor Firmware Version: .....	Indicates the current loaded firmware in this sensor. (Readable only)

## General Diagnostics

### POSSIBLE PROBLEM:

No Communications

Temperature Value Incorrect

Humidity Value Incorrect

No Setpoints

### POSSIBLE SOLUTIONS:

- Check and verify sensor address, Baud, stop bits, parity and address offset.  
- Check wiring polarity

- Check internal offset

- Check internal offset

- Check enable flags

## Specifications

### **Power:**

9 to 40 VDC (24 VDC nominal)  
24 VAC +20%/-30%.

Note: AC power requires a separate pair of shielded wires.

**Power Consumption:** 7 mA max DC;  
.28 VA max AC

**Sensing Element:** Thermistor or Semiconductor

**Wiring:** See Termination Section

**Terminals:** 22 to 14AWG

**Mounting:** Standard 2 x 4" box or drywall direct  
(Screws provided)

### **User Interface:**

Setpoint ..... Up & Down buttons  
Override..... Pushbutton  
Scroll..... Display of additional  
Sensor Parameters

### **Sensor Accuracy:**

Temperature: .... ±0.2°C from 32 to 122°F (0 to 50°C)  
%RH: ..... ±2%RH @ 25°C (77°F), 20 to 80%RH

**Display:** LCD, 2"W x 1.1"H Overall, 3.5 Digits@0.6"H  
ICONS ..... BAPI-Man, Heat, Cool, Inside, Outside,  
Auto, Off , On , Fan, Remote

Resolution..... Whole, Half or Tenths (Process variables)  
Setpoints ..... 0.5°F, 0.1°C or 1.0% steps  
Range ..... -40 to 185°F (-40 to 85°C), 0 to 100%

### **Setup Options:**

See "Optional Technician's Adjustments" section

### **Environmental Ambient:**

Temperature..... 32 to 122°F (0 to 50°C)  
Humidity ..... 0 to 95% RH Non-condensing  
Storage ..... 32 to 158°F (0 to 70°C)

**Material:** ABS Plastic, UL94V-0

**Agency:** RoHS and CE

Specifications subject to change without notice.



34350\_ins\_B54\_modbus

rev. 02/02/18

# BAPPI-Stat 4 Sensor with LCD and Digital Setpoints

## BAPPI-Stat 4 Modbus Temperature or Temp/Humidity Sensor

### Installation & Operating Instructions

## Modbus Register Allocation and Map

BAPPI Modbus Register Allocation and Map

Revision 01.06

Name/Description	Network Register			Data Format	Application Units	Read/Write	Bit Allocation															
	HEX	DEC	Size				Bit 15	Bit 14	Bit 13	Bit 12	Bit 11	Bit 10	Bit 9	Bit 8	Bit 7	Bit 6	Bit 5	Bit 4	Bit 3	Bit 2	Bit 1	Bit 0
Device ID	0	0	1	Bit Flags (See bit definition)		R															Humidity	Temperature
Device Status	1	1	1	Bit Flags (See bit definition)		R															Humidity	Temperature
Temperature Config	2	2	1	Bit Flags (See bit definition)		R/W															Base	RESERVED
Humidity Config	3	3	1	Bit Flags (See bit definition)		R/W															RH SP	RH
Occupancy Config	7	7	1	Bit Flags (See bit definition)		R/W															OVR	
Fan Config	8	8	1	Bit Flags (See bit definition)		R/W															FAN(1)	FAN(0)
Mode Config	9	9	1	Bit Flags (See bit definition)		R/W															HCA(0)	
Digital IN Value (1)	20	32	1	Bit Flags (See bit definition)		R															C or F	OVR
Digital Out Value (1)	40	64	1	Bit Flags (See bit definition)		R/W															Rsp LO	Tsp LO
Temperature (1)	60	96	1	short xxx.xx	Degrees	R/W																
Temperature Set-Point BASE	61	97	1	short xxx.xx	Degrees	R/W																
Temperature Set-Point COOL	62	98	1	short xxx.xx	Degrees	R/W																
Temperature Set-Point HEAT	63	99	1	short xxx.xx	Degrees	R/W																
Temperature Set-Point HEAT	64	100	1	short xxx.xx	Degrees	R/W																
User Set-Point limit low in °F	65-68	105	1	short xxx.xx	Degrees	R/W																
User Set-Point limit high in °F	69	106	1	short xxx.xx	Degrees	R/W																
User Set-Point limit low in °C	6A	107	1	short xxx.xx	Degrees	R/W																
User Set-Point limit high in °C	6B	108	1	short xxx.xx	Degrees	R/W																
User Set-Point limit high in °C	6C	109	1	short xxx.xx	Degrees	R/W																
Humidity	80	128	1	ushort xxx.xx	Percent	R/W																
Humidity Set-Point	81	129	1	ushort xxx.xx	Percent	R/W																
Humidity Set-Point Limit Low	82	130	1	ushort xxx.xx	Percent	R/W																
Humidity Set-Point Limit High	83	131	1	ushort xxx.xx	Percent	R/W																
LCD Mode Status	CO	192	1	enum		R/W															AUTO	OFF
LCD Fan Status	CI	193	1	enum		R/W															ON	FAN
LCD Status	C2	194	1	enum		R/W															ON	HIGH
Fan Status	140	320	1	enum		R/W															REMOTE	COOL
Mode Status	141	321	1	enum		R/W															LOU	HEAT
Diagnostic Flag Register	200	512	1			R															INSIDE	Enabled
Network Message Counter Value	201	513	1			R																
CRC Error Counter Value	202	514	1			R																
Slave Exception Counter Value	203	515	1			R																
Slave Message Counter Value	204	516	1			R																
Slave NonResponse Counter Value	205	517	1			R																
Framing and Overrun Counter Value	206	518	1			R																
Autotest/Reset/etc	207	519	1	Factory use only		R/W																
Address Bank Offset	20A	522	1	Integer (0-6) Allowed		R/W																
Badid	20B	523	1	Integer (0-2) Allowed		R/W																
Stop Bits	20C	524	1	Integer (1,2) Allowed		R/W																
Parity	20D	525	1	Integer (0,1,2) Allowed		R/W																
Register TOP	FFF	4095																				
Reserved	1000	4096		0x1000 through 0xFFFF reserved																		
Reserved	EFFE	61499		0x1000 through 0xFFFF reserved																		
Monitor Name ID, Serial #, Revision	FOOD	61440	16	B54M1BH1389734M0D790128P401.40101	ascii	R																Example shown

### Fan Status and Fan Display Icon Values

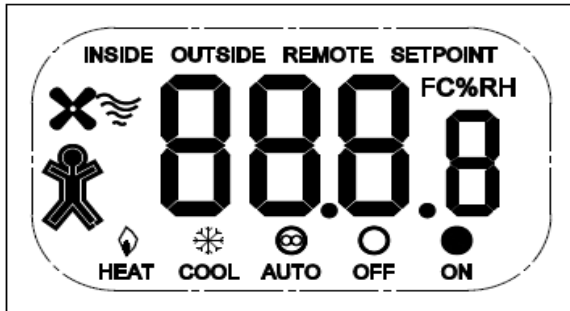

#### FAN Mode

FAN(0)	Fan Status Value	LCD INFO
	0	FAN, 1st Wave, OFF
	1	FAN, 1st and 2nd Waves
	2	FAN, 1st, 2nd and 3rd Waves
	3	FAN, 1st, 2nd, 3rd and 4th Waves

#### MODE mode

HCA(0)	Mode Status Value	LCD INFO
	0	HEAT
	1	COOL
	2	AUTO

#### FAN(1)

Fan Status Value	LCD INFO
0	FAN, 1st Wave, OFF
1	FAN, 1st and 2nd Waves
2	FAN, 1st, 2nd and 3rd Waves
3	FAN, 1st, 2nd, 3rd and 4th Waves
4	FAN, 1st, 2nd, 3rd, 4th Waves and ON
5	FAN, 1st, 2nd, 3rd, 4th Waves and AUTO

#### Fan Mode

FAN(2)	Fan Status Value	LCD INFO
	0	No FAN icon
	1	FAN, 1st Wave
	2	FAN, 1st and 2nd Waves
	3	FAN, 1st, 2nd and 3rd Waves
	4	FAN, 1st, 2nd, 3rd and 4th Waves

#### FAN(3)

Fan Status Value	LCD INFO
0	No FAN icon
1	FAN, 1st Wave
2	FAN, 1st and 2nd Waves
3	FAN, 1st, 2nd and 3rd Waves
4	FAN, 1st, 2nd, 3rd and 4th Waves
5	FAN, 1st, 2nd, 3rd, 4th Waves and AUTO